

VREF72 Upright

laboratory refrigerators



Solid door

Glass door



Features

Powerful refrigeration system with low GWP refrigerant for high performance and reduced total cost of ownership

- exclusive dual top-mounted modular Complete Refrigeration System (CRS)
- all refrigeration components external to storage compartment for greater usable capacity
- high volume airflow design for faster temperature recovery and uniform temperature

Protection for your valuable products

- audible and visual high/low temperature and door open alarms
- dry contacts for remote alarming
- access port for third party monitoring
- key door lock
- rear mounted on/off power switch

Precise temperature control

- microprocessor control with digital temperature display
- factory preset at 4 C (adjustable from 1 C to 12 C)

Laboratory-grade cabinet construction

- full steel interior and exterior provide resistance to rust and corrosion
- internal rounded corners
- heavy-duty dual casters roll easily and lock securely
- 2.36" (5.99 cm) of CARB compliant non-HFC foam throughout
- twelve epoxy-coated shelves standard

Heavy-duty door for ease of use and energy savings

- self-closing hinges lock open at 105° for easy product loading
- energy efficient low-E glass coating to reduce energy loss
- glass remains condensation-free to 27 C (80 F) at 60% RH

Engineered for sustainability

- R290 low GWP refrigerant
- high density foamed in place insulation (Kyoto Protocol compliant)
- energy-efficient LED lights
- ENERGY STAR® certified
- SNAP compliant
- cULus Listed and UL Energy Verified

Warranty

- 2 years parts and labor, 3 year compressor parts

Model configurations			
Hinging	Heated door	Door style	Item number
right	yes	glass	VREF72-LB-RGD
right	no	solid	VREF72-LB-RSD

Factory-installed options

Solid stainless steel door with 2.60" (6.60 cm) thick insulation and ADA-compliant full-length locking handle (full-length glass door standard)

NOTE: Factory-installed options must be specified at time of order – for details contact factory or your local sales representative.

Accessories

Replacement CRS (Complete Refrigeration System) module (item# 01394469)

Additional shelf (1) (item# 01394030)

NOTE: Accessories ship separately.

Specification

Nominal capacity	74.2 cu ft (2101 L)
Ventilation clearance	15.00" (38.1 cm) top, 2.00" (5.08 cm) back

Exterior

W1 Width	85.03" (216.0 cm)
D1 Depth with handle	glass door – 33.23" (84.4 cm) solid door – 31.50" (80.0 cm)
H1 Height with casters	79.31" (201.4 cm)
Casters	(10) swiveling dual wheel casters (2) with toe locks
D2 Door swing	55.91" (142.0 cm)
Wall bracket, seismic anchoring	standard, factory installed

Interior

Height	59.84" (152.0 cm)
Lighting	glass door – full length LED light on handle side of door solid door – (2) LED lights from top of cabinet
Storage system	(12) full, epoxy-coated shelves
Shelf dimensions	20.87" W x 25.59" D (53.0 x 65.0 cm)
Max. load rating per shelf	100 lb (45 kg)

Door configurations

Door	dual-pane glass door or solid powder coated steel (non-field reversible)
Door lock	cylinder type with key
Door handle	glass door – bar type solid door – ADA-compliant, full length handle
Door hinges	torsion rod self-closing with 105° hold open feature
Gasket	magnetic dart style (replaceable)

Electrical

C1 Electrical 115 V/60/1 (103 - 132 V)	7 run load amps, hospital-grade NEMA 5-15P plug, 118" (3.0 m) cord
Maximum size of branch circuit overcurrent device	15 amps dedicated circuit

Controls

Temperature display	standard 7 segment LED
C2 3rd party probe access	soft access port on left side of cabinet
Temperature probe calibration	top probe calibration in 0.1° increments
Refrigeration and defrost probes	NTC thermistor type (± 1.0 C, ± 1.8 F)
Programmable operating range	1 to 12 C (34 to 54 F)
Factory preset	4 C

Alarming

High and low product temperature alarm	audible and visual (preprogrammed)
Door ajar alarm	audible and visual
Probe error alarm	audible and visual
Alarm mute	with press of key
Remote contacts	NO/NC standard, located on back of unit

Dimensional drawing

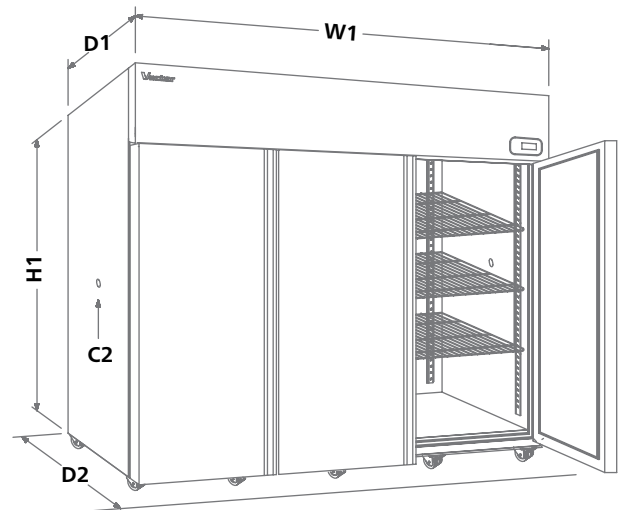

ENERGY STAR and the ENERGY STAR mark are registered trademarks owned by the U.S. Environmental Protection Agency.
VECTOR is a registered trademark of Follett Products, LLC, registered in the US.
Follett reserves the right to change specifications at any time without obligation.

System performance

Refrigeration system	(2) integral top-mounted modules with 1/5 hp compressor and air-cooled condenser
Refrigerant and charge	low GWP R290 refrigerant, (2) with 3.2 oz each
Air circulation system	evaporator with air-forced ventilation
Energy consumption	8.32 kWh/day (auto-off defrost)

Shipping

Shipping size	88" W x 34.50" D x 86.38" H (224 x 87.6 x 219.4 cm)
Approximate refrigeration module net weight	66 lb (30 kg)
Approximate net weight	solid door models – 636 lb (289 kg) glass door models – 717 lb (325 kg)
Approximate ship weight	solid door models – 699 lb (317 kg) glass door models – 772 lb (350 kg)

NOTE: For indoor use only

SHORT FORM SPECIFICATION: ENERGY STAR certified 74.2 cu ft (2101 L) upright 4 C refrigerator with (12) adjustable epoxy coated wire shelves. Low GWP R290 refrigeration system includes (2) integral top-mounted modules with 1/5 hp compressor and air-cooled condenser. Microprocessor control with digital display in degrees C. High density foamed in place insulation (Kyoto Protocol compliant). Full suite of audible and visual alarms. 118" (3.0 m) power cord with NEMA 5-15P hospital-grade plug.

VREF72 upright laboratory refrigerators

